

FCU COMPACT FOUR-WAY CASSETTE, 4 PIPES

MODEL			SF-300C4M	SF-400C4M	SF-500C4M		
Power supply		V/Ph/Hz		220-240/1/50			
Air flow (H/M/L)		m³/h	493/395/295	669/523/415	673/526/425		
		CFM	290/232/173	393/307/244	395/309/250		
Cooling	Capacity (H/M/L)	kW	2,16/1,86/1,49	2,78/2,38/2,05	2,77/2,38/2,07		
	Water flow rate	m³/h	0,42/0,37/0,3	0,53/0,46/0,4	0,56/0,49/0,43		
	Water pressure drop	kPa	17,4/13,5/9,3	13,15/9,4/7	16,8/13,1/10,3		
Heating	Capacity (H/M/L)	kW	3,56/2,99/2,36	4,25/3,58/3,02	4,51/3,79/3,22		
	Water flow rate	m³/h	0,36/0,31/0,25	0,41/0,36/0,31	0,47/0,4/0,36		
	Water pressure drop	kPa	29,8/21,7/14,3	30,4/22,2/16,7	36,1/25,9/19		
Max. power input		W	24	38	42		
Sound pressure level (H/M/L)		dB(A)	39/33/27	42/35/30	44/39/31		
Sound power level (H/M/L)		dB(A)	51/45/39	54/47/42	56/51/43		
Fan motor	Type		DC motor	DC motor	DC motor		
	Quantity		1	1	1		
Fan	Type		Centrifugal, forward-curved blades				
	Quantity		1	1	1		
Coil	Row		2	2	2		
	Max. working pressure	MPa	1,6	1,6	1,6		
	Diameter	mm	Φ7	Φ7	Φ7		
Panel	Net dimensions (WxHxD)	mm	647x50x647	647x50x647	647x50x647		
	Packing size (WxHxD)	mm	715x123x715	715x123x715	715x123x715		
	Net weight	kg	2,5	2,5	2,5		
	Gross weight	kg	4,5	4,5	4,5		
Body	Net dimensions (WxHxD)	mm	575x261x575	575x261x575	575x261x575		
	Packing size (WxHxD)	mm	675x320x675	675x320x675	675x320x675		
	Net weight	kg	16,7	16,7	16,7		
	Gross weight	kg	22,7	22,7	22,7		
Pipe connections	Water inlet/outlet pipe	inch	Cold water: G3/4; Hot water: G1/2				
	Drain pipe	mm	Φ25	Φ25	Φ25		
ADDITIONAL TECHNICAL INFORMATION							
Recommended power cable	Below 20 m	mm²	3x2,5	3x2,5	3x2,5		
Recommended air switch		A	B16	B16	B16		
EQUIPMENT							
Drain pump			yes	yes	yes		
Max. lift (from bottom of ID)		mm	600	600	600		
Built-in 3-way valve			no	no	no		
Control 2 or 3-way valve			yes (230V)	yes (230V)	yes (230V)		
Alarm connector			yes (230V)	yes (230V)	yes (230V)		
ON/OFF connector			yes (dry-contact)	yes (dry-contact)	yes (dry-contact)		
Fresh air inlet		mm	Φ75	Φ75	Φ75		
BMS modbus RTU			yes	yes	yes		
STANDARD ACCESSORIES							
Water outlet joint			yes	yes	yes		
Clasp			yes	yes	yes		
Copper nut			yes	yes	yes		
Remote controller (IR)			R05	R05	R05		
OPTIONAL ACCESSORIES							
Wire controller			KJR-29B	KJR-29B	KJR-29B		
Central controller			SCM-30	SCM-30	SCM-30		

Note: H: High fan speed; M: Medium fan speed; L: Low fan speed. Cooling mode: entering air temperature 27 °C DB/19 °C WB, entering/leaving water temperature 7 °C /12 °C. Heating mode: entering air temperature 20 °C DB, enter water teperature 50 °C. The specification of products is subject to change based on further development of the units by the producer and can be changed without prior notice. Refer to rating label.

APPEARANCE AND DIMENSIONS OF INDOOR UNITS

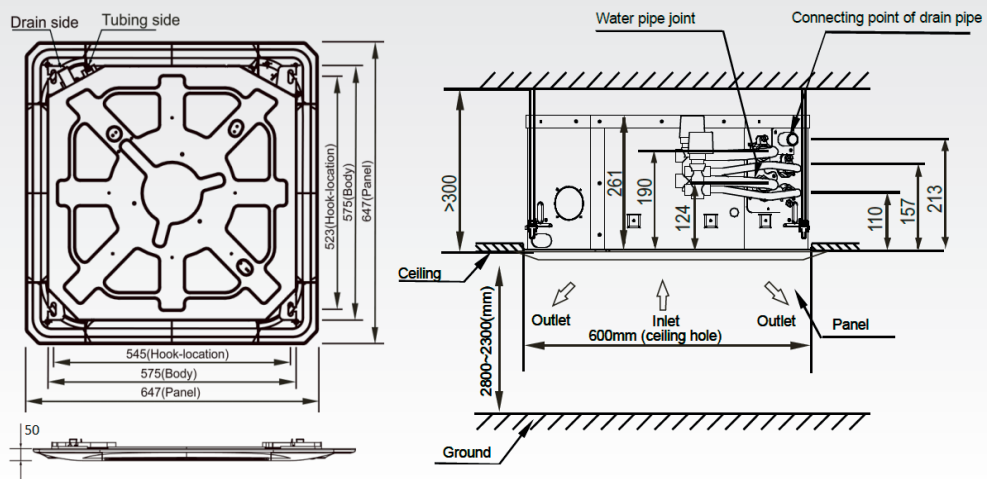

INDOOR UNITS

FCU SF2 FOUR-WAY CASSETTE, 4 PIPES

MODEL			SF2-600C4	SF2-700C4	SF2-800C4		
Power supply		V/Ph/Hz	220-240/1/50				
Air flow (SH/MH/H/ML/MLS)		m³/h	1020/930/870/800/ 720/620/520	1190/1080/950/880/ 790/680/560	1360/1250/1120/1000/ 900/800/660		
		CFM	600/547/511/470/ 423/364/305	700/635/558/517/ 464/400/329	800/735/658/588/ 529/470/388		
Cooling	Capacity (SH/MH/H/ML/MLS)	kW	4,70/4,40/4,00/3,70/3,40/ 3,00/2,65	5,00/4,70/4,40/4,15/3,90/ 3,55/3,00	5,50/5,20/4,90/4,60/4,20/ 3,80/3,40		
	Water flow rate	m³/h	0,88/0,82/0,74/0,65/0,60/ 0,53/0,46	0,90/0,88/0,83/0,77/0,74/ 0,67/0,63	1,02/0,98/0,92/0,86/0,76/ 0,69/0,62		
Heating	Capacity (SH/MH/H/ML/MLS)	kW	7,30/6,90/6,40/6,00/5,30/ 4,40/3,80	7,00/7,00/6,70/6,40/6,30/ 5,50/4,65	7,50/7,10/6,70/6,35/5,95/ 5,50/5,20		
	Water flow rate	m³/h	0,68/0,63/0,59/0,55/0,50/ 0,41/0,33	0,71/0,68/0,64/0,61/0,57/ 0,51/0,41	0,79/0,74/0,69/0,63/0,59/ 0,53/0,46		
Water pressure drop		kPa	30/28/26/25/22/16/14	35/32/30/27/25/20/15	40/35/30/28/22/18/17		
Max. power input		W	40	45	60		
Sound pressure level (SH/MH/H/ML/MLS)		dB(A)	34,2/31,5/29,0/26,3/24,1/ 21,8/20,6	37,4/34,5/31,6/28,4/25,6/ 23,2/21,0	41,2/38,6/35,7/32,2/28,9/ 25,6/22,8		
Sound power level (SH/MH/H/ML/MLS)		dB(A)	46,8/44,1/41,4/38,4/35,4/ 32,4/30,3	49,7/47,1/44,2/41,2/37,9/ 35,0/31,8	53,5/50,9/48,0/44,9/41,6/ 38,0/35,1		
Fan motor	Type		DC motor	DC motor	DC motor		
	Quantity		1	1	1		
Fan	Type		Centrifugal, forward-curved blades				
	Quantity		1	1	1		
Coil	Row		2	2	2		
	Max. working pressure	MPa	1,6	1,6	1,6		
	Diameter	mm	Φ7	Φ7	Φ7		
Panel	Net dimensions (WxHxD)	mm	950x77x950	950x77x950	950x77x950		
	Packing size (WxHxD)	mm	1020x90x1020	1020x90x1020	1020x90x1020		
	Net weight	kg	5,8	5,8	5,8		
	Gross weight	kg	7,6	7,6	7,6		
Body	Net dimensions (WxHxD)	mm	840x288x840	840x288x840	840x288x840		
	Packing size (WxHxD)	mm	940x335x940	940x335x940	940x335x940		
	Net weight	kg	23,9	23,9	23,9		
	Gross weight	kg	26,4	26,4	26,4		
Pipe connections	Water inlet/outlet pipe	inch	RC3/4	RC3/4	RC3/4		
	Drain pipe	mm	Φ25	Φ25	Φ25		
ADDITIONAL TECHNICAL INFORMATION							
Recommended power cable	Below 20m	mm²	3x2,5	3x2,5	3x2,5		
Recommended air switch		A	B16	B16	B16		
EQUIPMENT							
Drain pump			yes	yes	yes		
Max. lift (from bottom of ID)		mm	1000	1000	1000		
Built-in 3-way valve			no	no	no		
Control 2 or 3-way valve			yes (230V)	yes (230V)	yes (230V)		
Alarm connector			yes (230V)	yes (230V)	yes (230V)		
ON/OFF connector			yes (dry-contact)	yes (dry-contact)	yes (dry-contact)		
Fresh air inlet		mm	Φ103	Φ103	Φ103		
BMS modbus RTU			yes	yes	yes		
OPTIONAL ACCESSORIES							
Remote controller (IR)			SRC-61	SRC-61	SRC-61		
Wire controller			SWC-61, SWC-62, SWC-63	SWC-61, SWC-62, SWC-63	SWC-61, SWC-62, SWC-63		
Central controller			SCM-30	SCM-30	SCM-30		
Control fan speed (H/M/L), ON/OFF, Alarm			SF2-CTK	SF2-CTK	SF2-CTK		
Control fan speed (0-10V), valve control 0-10V			SF2-EC*	SF2-EC*	SF2-EC*		

*SF2-EC require SF2-CTK

Cooling mode: entering air temperature 27°C DB/19°C WB, entering/leaving water temperature 7°C /12°C.

Heating mode: entering air temperature 20°C DB, entering/leaving water temperature 45/40°C.

Sound power levels are measured 1m around the unit in a semi-anechoic chamber. During in-site operation. Sound pressure levels are measured 1m below and right of the unit in a semi-anechoic chamber.

The specification of products is subject to change based on further development of the units by the producer and can be changed without prior notice. Refer to rating label.

APPEARANCE AND DIMENSIONS OF FAN COIL UNIT

FCU SF2 FOUR-WAY CASSETTE, 4 PIPES

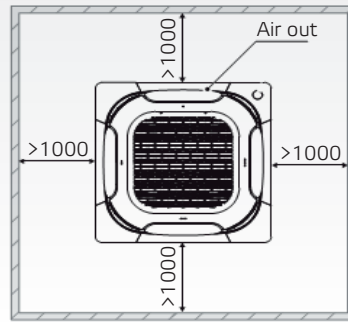
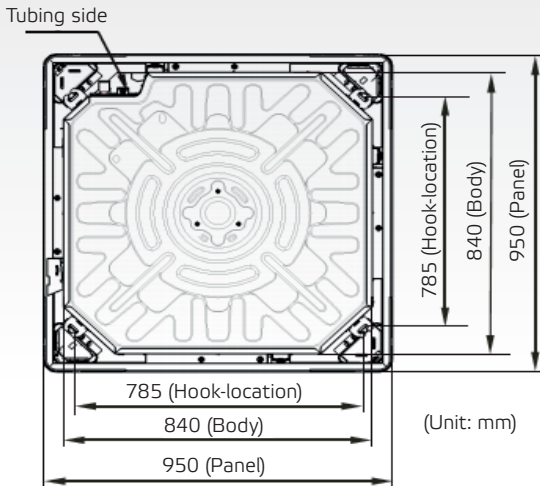

Model	Size (mm)	A	B	C	D	E	F
SF2-600C2		140	103	323	85	155	204
SF2-700-1200C2		140	103	323	160	230	288
SF2-600-1200C4							

