

CASSETTE INDOOR UNITS

MULTI VARIABLE SERIES

MODEL			MV-C12BI	MV-C18BI	MV-C24BI		
Capacity cooling/heating 1)	Nominal	kW	3,4/4,0	4,5/5	7,1/8		
Power supply		Hz / V	1~ / 50 / 220-240	1~ / 50 / 220-240	1~ / 50 / 220-240		
Air flow of ID	SH/H/M/L	m ³ / h	650/560/520/450	710/670/590/450	1280/1220/1100/880		
Sound pressure level of ID at 1,4m 4)	SH/H/M/L	dB(A)	44/41/38/34	47/45/41/35	47/45/41/36		
Sound power of ID 4)	SH/H/M/L	dB(A)	55/52/49/45	58/56/52/46	58/56/52/47		
External static pressure	nom/min-max	Pa	-	-	-		
Dehumidifying volume		l / h	1,4	1,8	2,5		
Refrigerant type		Type	R32	R32	R32		
Pipe diameter - liquid side 5)		inch / mm	¼ / 6,0	¼ / 6,0	¾ / 9,5		
Pipe diameter - gas side 5)		inch / mm	¾ / 9,5	¾ / 12,0	¾ / 16,0		
Dimension of ID	w x h x d	mm	596x596x240	596x596x240	840x840x240		
Dimension of panel	w x h x d	mm	670x50x670	670x50x670	950x60x950		
Package dimension of ID	w x h x d	mm	778x738x300	778x738x300	963x963x325		
Package dimension of panel	w x h x d	mm	763x105x763	763x105x763	1033x133x1038		
Weight of ID	netto / brutto	kg	20/24	20/24	26/32		
Weight of panel	netto / brutto	kg	3,5 / 5,0	3,5 / 5,0	7,0 / 11,0		
Set temperature range		°C	16 ~ 30	16 ~ 30	16 ~ 30		
ADDITIONAL TECHNICAL INFORMATION							
Screw holes distance	w x d	mm	See service manual				
Communication cable		mm ²	4x1,0	4x1,0	4x1,0		
Recommended power cable 11)		mm ²	Outdoor unit power supplied				
Recommended air switch		A	Outdoor unit power supplied				
EQUIPMENT							
Plasma generator			no	no	no		
Wifi module			no	no	no		
Drain pump			yes	yes	yes		
Max. lift (from bottom of ID unit)		mm	500	500	500		
Dry contact (ON/OFF)			yes	yes	yes		
Alarm contact			no	no	no		
Fresh air inlet			yes	yes	yes		
STANDARD ACCESSORIES							
Standard health filter			-	-	-		
Remote controller (IR)			YT1F	YT1F	YT1F		
Wired controller			yes	yes	yes		
OPTIONAL ACCESSORIES							
Optional health filters				-			
Wired controller				SWC-02			
Central controller				SCC-16			
Other				G2S			

The specification of products is subject to change based on further development of the units by the producer and can be changed without prior notice. Refer to rating label.

R32 (single component refrigerant HFC), GWP of refrigerant used: 675.

Contains fluorinated greenhouse gases covered by the Kyoto Protocol.

Explanatory notes on the very last page of the catalogue.

These indoor units may be combined with other indoor units from MULTI VARIABLE series, it is essential to follow combinations recommended in the combination table.

APPEARANCE AND DIMENSIONS OF INDOOR UNIT

MV-C12BI

MV-C18BI

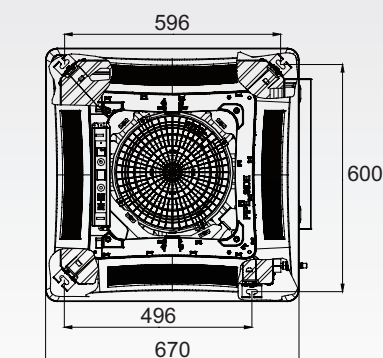

MV-C24BI

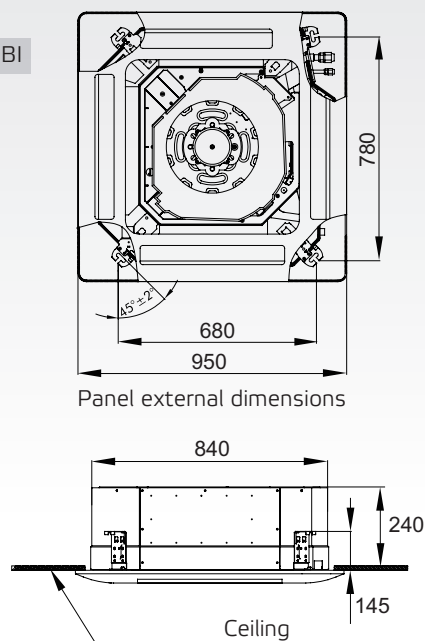

Panel external dimensions

units: mm